



MULTI-INNO TECHNOLOGY CO., LTD.

LCD MODULE SPECIFICATION

Model : MI0430FT-3

Revision	1.0
Engineering	
Date	
Our Reference	



History of Versions and Modifications

Version	Modifications	Date
1.0	Generation first version	2008-9-10



PRODUCT SPECIFICATIONS

- ◆ **MODULE CLASSIFICATION INFORMATION**
- ◆ **LCD MODULE PHYSICAL DATA**
- ◆ **EXTERNAL DIMENSIONS**
- ◆ **BLOCK DIAGRAM**
- ◆ **ABSOLUTE MAXIMUM RATINGS**
- ◆ **ELECTRICAL CHARACTERISTICS**
- ◆ **TOUCH SCREEN PANEL SPECIFICATIONS**
- ◆ **INTERFACE PIN CONNECTIONS**
- ◆ **RECOMMEND INITIAL CODE**
- ◆ **ELECTRO-OPTICAL CHARACTERISTICS**
- ◆ **SPECIFICATION OF QUALITY ASSURANCE**
- ◆ **RELIABILITY**
- ◆ **SUGGESTIONS FOR USING LCD MODULES**
- ◆ **PACKING**
- ◆ **ENVIRONMENT-RELATED SUBSTANCES**



◆ **MODULE CLASSIFICATION INFORMATION**

MI 0430 FT - 3

MI: MULTI-INNO standard module

0430: Display Size 4.3 inch

F : Serial Number

T:Display Mode

T : TFT module

-3 : Product Version: 1,2,3,4..

◆ LCD MODULE PHYSICAL DATA

● General Description

Display Type	16.7M TFT
Display Mode	POSITIVE
Viewing Direction	6 o'clock
Connection Type	COG
Operation temperature	-20℃ ~70℃
Storage temperature	-30℃ ~80℃
Driving IC	HX8257

● Mechanical Description

Item	Standard Value	Unit
Number of dots	480BGR×272dots	-
LCM dimension	105.50(W)×67.20(H)×5.10(T)	mm
TP viewing area	97.70(W)×55.90(H)	mm
TP active area	95.44(W)×54.26(H)	mm
Active area	95.04(W)×53.86(H)	mm
Dot size	0.188(W)×0.188(H)	mm
Dot pitch	0.198(W)×0.198(H)	mm
Backlight	12 chip white LEDS	/
The KEY and accessory materials of our product according with BHS-001 standard		

◆ EXTERNAL DIMENSIONS

CUSTOMER'S MODEL NO.:

CUSTOMER APPROVED:

DATE:

PIN	description	PIN FUNCTION
1	VLED-	VLED-
2	VLED+	VLED+
3	GND	
4	VDD	
5	RO	
6	R1	
7	R2	
8	R3	
9	R4	
10	R5	
11	R6	
12	R7	
13	G0	
14	G1	
15	G2	
16	G3	
17	G4	
18	G5	
19	G6	
20	G7	
21	B0	
22	B1	
23	B2	
24	B3	
25	B4	
26	B5	
27	B6	
28	B7	
29	GND	
30	PCLK	
31	DISP	
32	HSTMC	
33	VSTMC	
34	DE	
35	AVDD	
36	GND	
37	XR	
38	YD	
39	XL	
40	YU	

VIEWING DIRECTION

REAR

FRONT

REMOVE TAPE

4.3 INCH
DOTS: 480X3 (RGB) * 272

Component Area

"A"

"B"

LED1+ LED1- LED2+ LED2-

BACKLIGHT DIAGRAM

DETAIL A

1	LED1-
2	LED2-
3	LED2+
4	LED1+

DETAIL B SCALE 4:1
TYPE:FH19S-40S-0.5SH(51)

NOTES:

1. DISPLAY TYPE:TFT 16.7M color
2. VIEWING DIRECTION: 6.0°CLOCK
3. POLARIZER: TRANSMISSIVE/POSITIVE
4. OPERATING TEMP: -20°C ~70°C
5. STORAGE TEMP: -30°C ~80°C
6. IC: COG HX8257
7. GENERAL TOLERANCE: ±0.2
8. * KEY DIMENSION
9. BHS-001
10. 建议泡棉开窗单边比TP VA大0.3mm以上。

REVISION RECORD		DATE	MULTI-INNO TECHNOLOGY CO.,LTD.	
1	TITLE: LCM OUTLINE DIMENSION		D/N : MI0430FT-3	
2	FILE NAME : 模组图	Rev. : 0	P/N :	
3	FILE NO. :	Ver. : X	SCALE : N.T.S.	
4	DRAWN BY	DATE	UNIT : mm	
5	CHECKED BY	DATE	PRO.(S) :	
6	CHECKED BY	DATE	SHEET : 1/1	

◆ BLOCK DIAGRAM

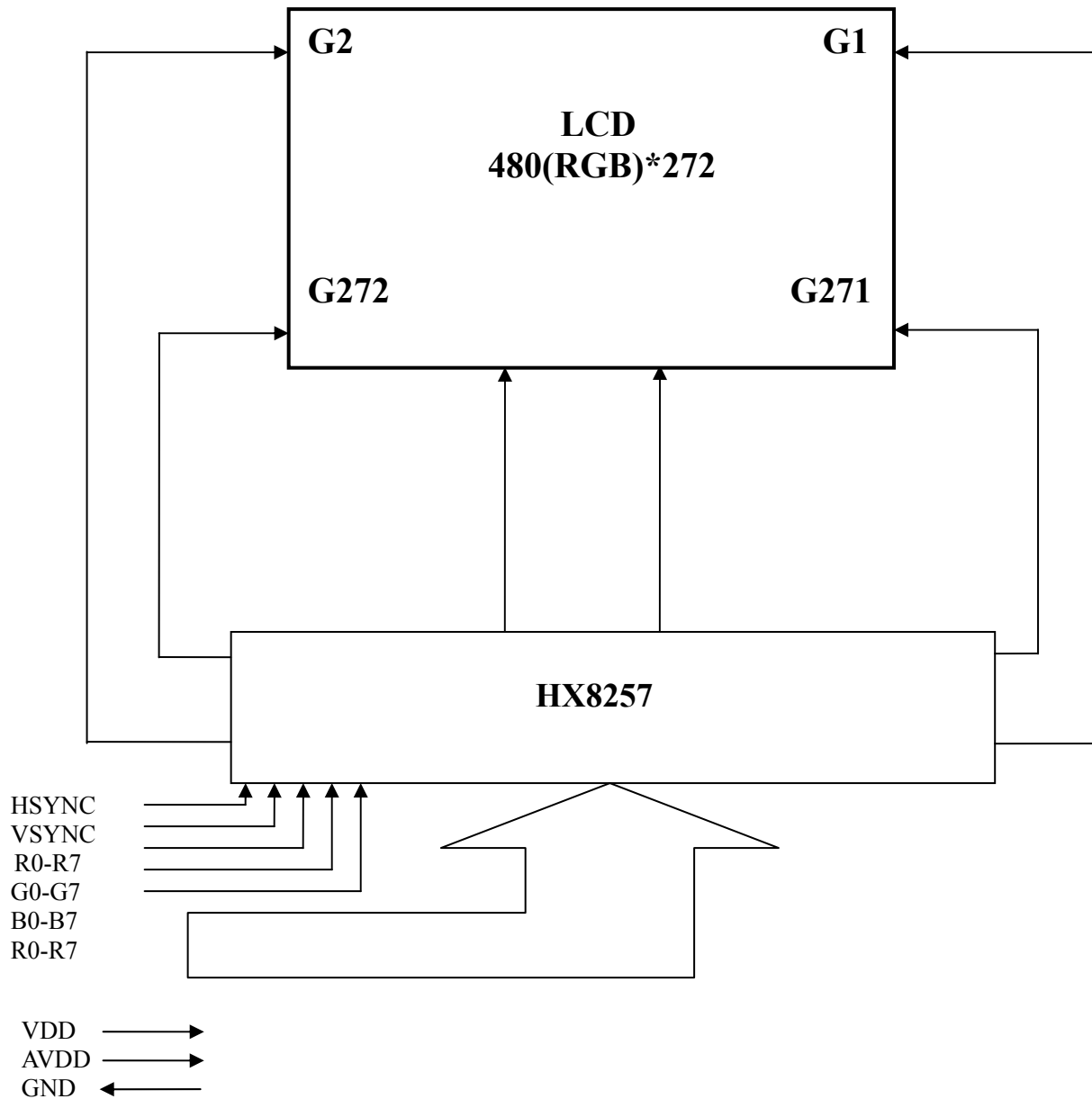

● Black Light Unite

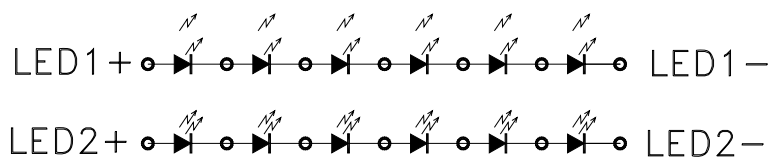

● **Touch Screen Panel(Top View)**

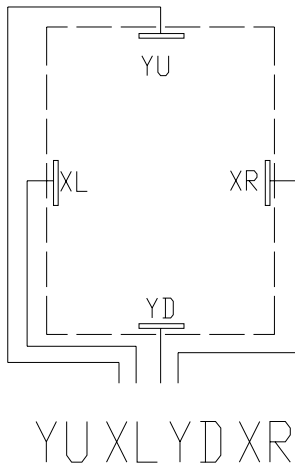

◆ **ABSOLUTE MAXIMUM RATINGS**

Item	Symbol	Rating	Unit
Operating temperature	Top	-20 to 70	°C
Storage temperature	Tst	-30 to 80	°C
Power Supply Voltage(2)	VDD	-0.3 to 4.0	V

NOTE:

1. If the module is used above these absolute maximum ratings. It may become permanently damaged. Using the module within the following electrical characteristic conditions are also exceeded, the module will malfunction and cause poor reliability.
2. VDD>GND must be maintained.

◆ ELECTRICAL CHARACTERISTICS

● DC Characteristics

Item	Symbol	Condition	Min	Typ	Max	Unit
Input high voltage	V_{IH}	-	0.8 VDD	-	VDD	V
Input low voltage	V_{IL}	-	0	-	0.2VDD	V
Supply voltage(1)	VCI	Ta=25°C	» VDDIO	3.3	3.6	-
Supply voltage(2)	VDDIO	Ta=25°C	-	-	-	V
			1.8	3.3	3.6	-
Logic dynamic current	IDD1	-	-	-	-	mA
Driver dynamic current	IDD2	-	-	-	-	mA

● Back-Light unit

Item	Symbol	Min	Typ	Max	Unit	Remark
Current	I_{BL}	-	16	-	mA	1 LED
CIE	X	0.25	-	0.29	-	X>Y
	Y	0.24	-	0.28	-	
Brightness	-	3800	-	4800	cd/m ²	-
Luminous Uniformity Ratio	-	80	-	-	%	-
Bezel(BE) must be connected to ground of the main board						

Note:

1. Average Luminous Intensity of P1 ~ P5 (Using a luminance meter BM-7)
 2. Luminous Intensity Ratio = min/max * 100%
- Measured Method (X*Y: Light Area).

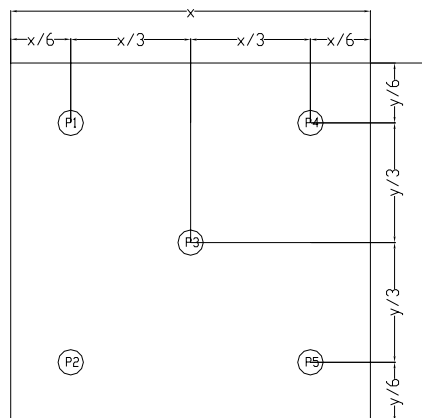

● AC Characteristics

Refer to the SPEC of HX8257

◆ TOUCH SCREEN PANEL SPECIFICATIONS

1. Electrical Characteristics

Item	Min	Typ	Max	Unit	Note
Linearity	-	-	1.5	%	X-Axis, Y-Axis
Terminal Resistance	140	-	640	Ω	X(Glass side)
	180	-	900	Ω	Y(Film side)
Insulation Resistance	10	-	-	MΩ	DC 25V
Operating voltage	-	-	5	V	DC
Response Time	-	-	10	Ms	-
Transmittance	73	-	-	%	-

Note 1) : Do not operate it with a thing except a polyacetal pen (tip R0.8mm or less) or a finger, especially those with hard or sharp tips such as a ball point pen or a mechanical pencil

2. Mechanical & Durability Characteristics

Item	Min	Typ	Max	Unit	Note
Operating Force	10	-	100	G	(1)
Touch Test	1,000,000	-	-	Times	(2)
Handwriting Friction Test	100,000	-	-	Times	(3)
Surface hardness	3	-	-	H	(4)

Note (1) Pen : 0.8N or less (R0.8mm)

Finger : 0.8N or less (0.8mm)

(2) Measurement for Center part of Panel

-Hitting Pad : Tip R8mm Silicon Rubber & Tip R0.8mm Stylus pen

-Lode : 150gf

-Speed : 2times/sec

-Electric lode : None

(3) Measurement for 2.0mm inside of transparent insulation

-Sliding Pen : Tip R0.8mm Stylus pen

-Lode : 150gf

-Speed : 60mm/sec

-Sliding Length : 25mm

-Electric lode : None

(4) Pressure 500gf, 45deg

3. Integration Design Guide

- Avoid the design that Front-case overlap and press on the active area of the touch-panel.
- Give enough gap (over 0.5mm at compressed) between the front case and touch-panel to protect wrong operating.
- Use a buffer material (Gasket) between the touch-panel and Front-case to protect damage and wrong operating.
- Avoid the design that buffer material overlap and press on the inside of touch-panel viewing area.

◆ INTERFACE PIN CONNECTIONS

NO.	Symbol	Function
1	VLED-	Backlight negative
2	VLED+	Backlight positive
3	GND	Ground
4	VDD	Power supply
5	R0	data bus(Red)
6	R1	
7	R2	
8	R3	
9	R4	
10	R5	
11	R6	
12	R7	
13	G0	data bus(Green)
14	G1	
15	G2	
16	G3	
17	G4	
18	G5	
19	G6	
20	G7	
21	B0	data bus(Blue)
22	B1	
23	B2	
24	B3	
25	B4	
26	B5	
27	B6	
28	B7	
29	GND	Ground
30	PCLK	Pixel clock singal
31	DISP	Display on/off control
32	HSYNC	Horizontal sync signal
33	VSNC	Vertical sync signal
34	DE	Data enable
35	AVDD	NC
36	GND	Ground
.37	XR	Touch panel interface
38	YD	
39	XL	
40	YU	

◆ ELECTRO-OPTICAL CHARACTERISTICS

Driving condition: VDD= 3.3V, I_{BL}=32mA, Temperature =23°C±5°C, Humidity=60%±20%RH

Item	Light angle (°)	Temp (°C)	Symbol	Specifications			Unit	Conditions	Note		
				Min.	Typ.	Max.					
Transmittance	0	25	-	-	6.1	-	%	(Equipment :BM-7/CS-200)	(1)		
Contrast ratio	0	25	Cr	-	450	-	-		(2)		
Brightness	0	25	-	280	310	-	cd/m ²		-		
Luminance uniformity (surface within panel)	0	25	Lu	70	80	-	%		(3)		
Cross talk	0	25	CTV	-	-	20	%		(4)		
Chromaticity	R x	0	25	Rx	0.5571	0.6071	0.6571	-	-		
	R y			Ry	0.3059	0.3559	0.4059				
	G x			Gx	0.2721	0.3221	0.3721				
	G y			Gy	0.5319	0.5819	0.6319				
	B x			Bx	0.0944	0.1444	0.1944				
	B y			By	0.0400	0.0900	0.1400				
	W x			Wx	0.2351	0.2851	0.3351				
	W y			Wy	0.2658	0.3158	0.3658				
Color Reproduction Area(NTSC)		0	25	-	-	57	-	%	CIE1931(x,y)	(5)	
Response time	Tr	0	25	-	-	5	-	ms	Viewing normal angle $\theta_x = \theta_y = 0^0$	-	
	Tf			-	-	15	-				
Viewing angle	Hor.	0	25	θ_{x+}	-	-	45	-	deg	Center CR≥10	-
				θ_{x-}	-	-	45	-			
	Ver.			θ_{y+}	-	-	15	-			
				θ_{y-}	-	-	35	-			

Note:

(1). Transmittance

Introduction

Transmittance (diffuse transmission factor) is a measure for the LCD panel transparency. The Light Source for this measurement is the accompanying LCD-module backlight system (LEDs, Lightguide...)

Measurement conditions:

Measuring Equipment	BM-7/CS-200
Measurement Point Diameter	3mm
Measurement Point Location	Active Area Center Point
Light source	LCD module backlight
Reflectance Plate	Reflectance Standard(cal. plate)
Test pattern	All pixels white
Contrast setting	Maximum

Measuring procedure:

Transmittance:

The light source is located at the backside of the panel.

- 1、 Measure the light source
- 2、 Place the LCD panel in front of the light source. Measure the luminance on the LCD panel surface

Definitions

$$\tau = \frac{L_{V_{LCD-panel}}}{L_{V_{lightsource}}} * 100\%$$

- (2) **Definition of Contrast Ratio (C/R):** Ratio of gray max (Gmax) & gray min (Gmin) at the center point.

$$CR = \frac{G(Max)}{G(Min)}$$

Where

Gmax: Luminance with all pixels white

Gmin: Luminance with all pixels black

- (3). **Surface luminance uniformity within panel**

Measurement conditions:

Measuring Equipment	CS200 // BM-7
Measurement Point Diameter	3mm // 1mm
Measurement Point Location	Active Area
Light Source	Transmissive Mode: Internal (Backlight)
Test pattern	White

Measuring procedure:

Measure the luminance Li with the points in figure 1.

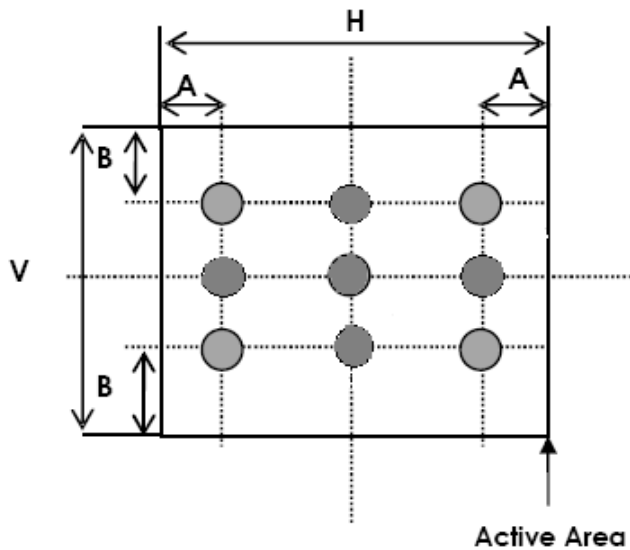
Figure 1

A: 5 mm B: 5 mm
H, V: Active Area

Uniformity value (Lu):

$$Lu = \frac{\min(Li)}{\max(Li)} * 100\%$$

(4). CROSS-TALK
Introduction:

Crosstalk is an effect where the contrast of a display pixel is influenced by the state of the related pixels. A measure for this effect is the Cross Talk Value (CTV)

Measurement conditions:

Measuring Equipment	CS200 // BM-7
Measurement Point Diameter	3mm // 1mm
Measurement Point Location	
Light Source	Transmissive Mode: Internal (Backlight)
Contrast setting	Maximum

• Test Pattern (valid for all greyscales):

W: The width of the rectangle in the following pictures;

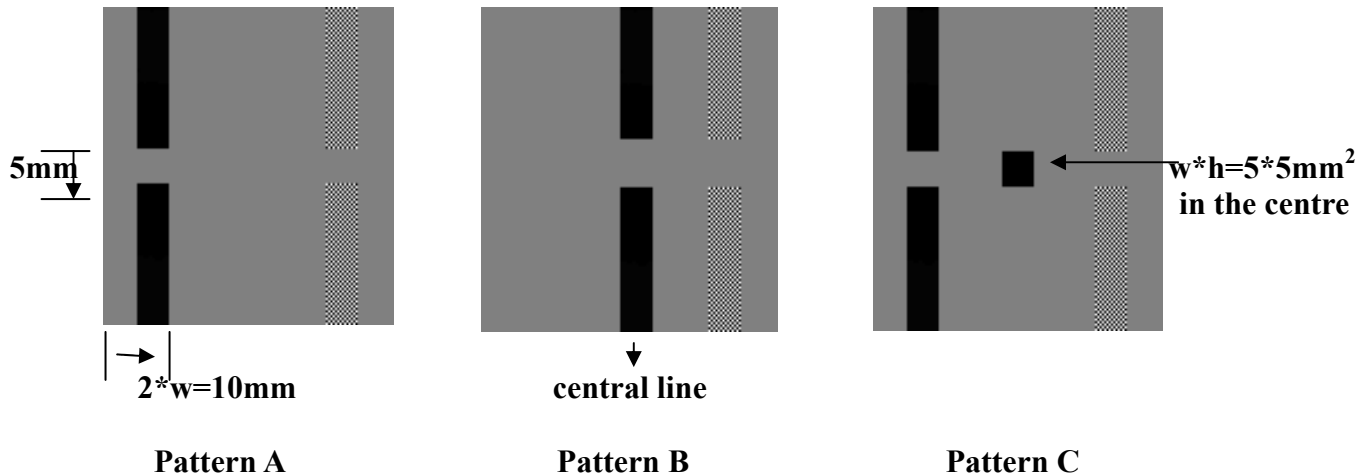

● **Definitions:**

Cross Talk Value:

$$CTV = |L_{vA} - L_{vB}| / L_{vA} * 100\%$$

Where:

L_{vA}: Luminance measured with the centre test point of pattern A

L_{vB}: Luminance measured with the centre test point of pattern B.

● **Measuring procedure:**

Adaptation of the display to the highest contrast ratio (CR = L_{vA}/L_{vC}) as defined by the test patterns and a test area of 14 x 14 dots.

Measurement of Luminance with test point A, B.

Determination of Crosstalk value (CTV)

(5). NTSC

Measurement conditions:

Measuring Equipment	LCD-5200
Measuring Point Diameter	3mm//1mm
Measuring point location	Active Area center point
Light source	Transmissive Mode: internal(Backlight)
Test pattern	All Pixels White Red.Green.Blue.White: Maximum colour saturation (maximum gradation level)
Contrast setting	Maximum

Definitions

Panel colour coordinates according the CIE colour system (CIE 1931). In general, It is always requested to measure the X, Y and Z values.

Here u', v' and L* are according CIE 1931:

$$x' = \frac{4 \cdot X}{X + 15 \cdot Y + 3 \cdot Z}$$

$$y' = \frac{9 \cdot Y}{X + 15 \cdot Y + 3 \cdot Z}$$

$$L^* = 116 \cdot \left(\frac{Y}{Y_n} \right)^{1/3} - 16$$

Colour distance definition (maximum allowed colour distance to specified typical colour coordinate):

$$\Delta x' y' = \sqrt{\Delta x'^2 + \Delta y'^2}$$

Where:

$$\Delta x' = \text{Max} \left\{ \left| x'_{typ} - x'_{max} \right|, \left| x'_{typ} - x'_{min} \right| \right\}$$

$$\Delta y' = \text{Max} \left\{ \left| y'_{typ} - y'_{max} \right|, \left| y'_{typ} - y'_{min} \right| \right\}$$

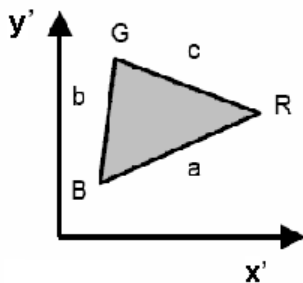

Color Gamut definition:

$$F = \sqrt{s(s-a)(s-b)(s-c)} * 1000$$

Where

$$s = \frac{(a+b+c)}{2}$$

$$a = \sqrt{(x'_{blue} - x'_{red})^2 + (y'_{blue} - y'_{red})^2}$$

$$b = \sqrt{(x'_{blue} - x'_{green})^2 + (y'_{blue} - y'_{green})^2}$$

$$c = \sqrt{(x'_{red} - x'_{green})^2 + (y'_{red} - y'_{green})^2}$$

Color Gamut Ratio (NTSC) related to NTSC':

NTSC: =F (display)/F (NTSC')

NTSC' primaries:

	x'	y'
Red	0.67	0.33
Green	0.21	0.71
Blue	0.14	0.08

$$F (\text{NTSC}') = 74.42$$

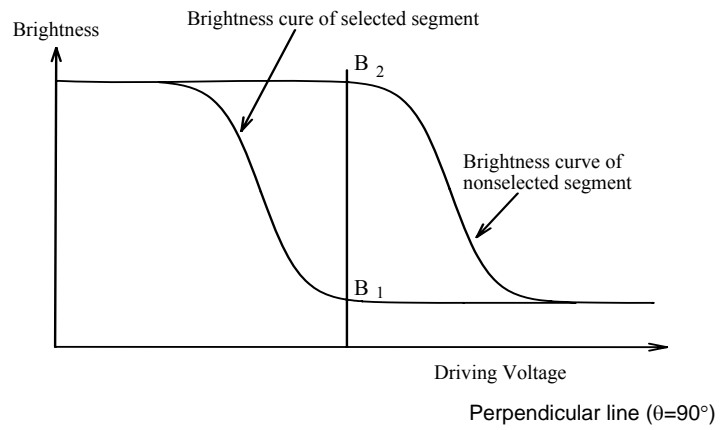
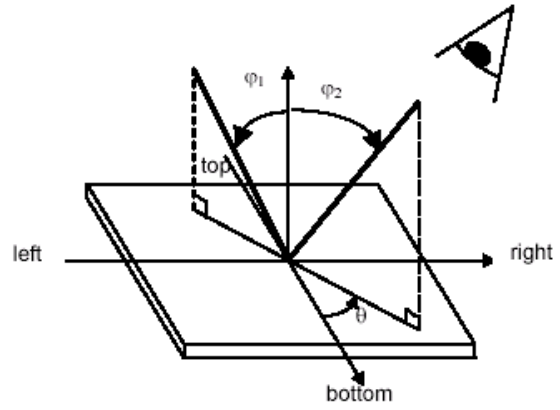
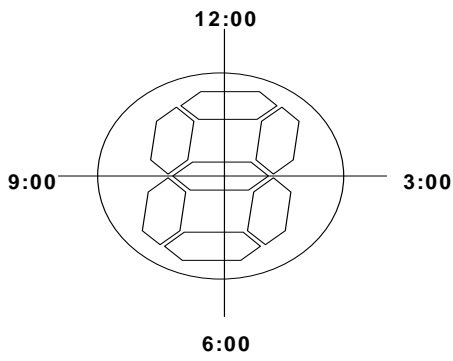

◆ SPECIFICATION OF QUALITY ASSURANCE

● Summary

The customer should check and accept the products of Multi-inno within one month after reception. This standard for quality assurance should affirm the quality of LCD products to supply to purchaser by Multi-inno technology co.,ltd. Entire process is controlled according to ISO9001.

● Warranty period

Warranty period of this product is 12 months from manufacture code.

● Standard for quality test

- 1、 Inspection
Before delivering, the supplier should take the following test, and confirm the quality of product.
- 2、 Electro-Optical Characteristics
According to the individual specification to test the product.
- 3、 Test of Appearance Characteristics:
According to the individual specification to test the product.
- 4、 Test of Reliability Characteristics
According to the definition of reliability on specification for test product.
- 5、 Delivery Test
Before delivering, the supplier should take the delivery test
- 6、 Sampling Method: GB/T2828.1-2003, Level II
- 7、 The defects classify of AQL as following

Major defect : AQL=0.65

Minor defect:: AQL= 1.5

● Nonconforming Analysis & Deal With Manners

✧ Nonconforming Analysis

- 1、 Purchaser should supply the detail data of nonconforming sample and the non-suitable state.
- 2、 After accepting the detail data from purchaser ,the analysis of nonconforming should be finished in two weeks.
- 3、 If supplier can not finish analysis on time ,must announce purchaser before two weeks.

✧ Disposition of nonconforming

- 1、 If find any supplier defect during assembly line, supplier must change the good product for every defect after recognition.
- 2、 Both supplier and customer should analysis the reason and discuss the disposition of nonconforming when the reason of nonconforming is not sure.

● Agreement items.

Both sides should discuss together when the following problems happen:

- 1、 There is any problem of standard of quality assurance, and both sides think that must be modifier.
- 2、 There is any argument item which does not record in the quality assurance.
- 3、 Any other special problem.

● Standard of the Product Appearance Test

■ Manner of appearance test

- 1、 The test must be under 20W*2 or 40W fluorescent light ,and the distance of view must be at 30±5

cm;

- 2、 When test the model of Transmissive product must add the reflective plate.
- 3、 The test direction is base on about around 30 degree(within θ range)of vertical line, and the test time is below 5s.

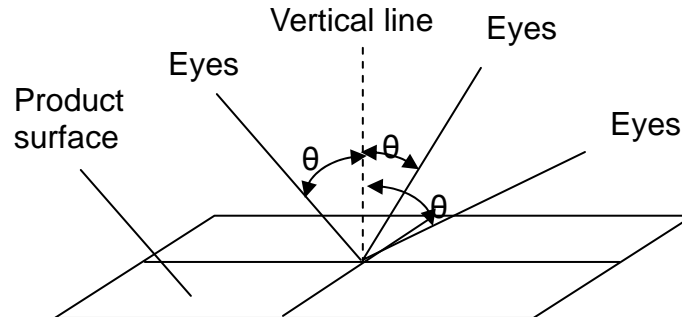

4、 Definition of Area:

- A Area: Active area
- B Area: Viewing area
- C Area: Out of viewing area
- D Area: Seal area

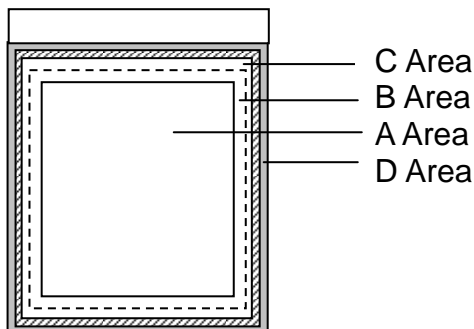

Note:

- A: Active Area is drawn in the drawing
- B: Viewing Area border is 2mm from Active Area border

■ Basic principle:

- 1、 It will accord to the AQL when the standard can not be described.
- 2、 The sample of the lowest acceptable quality level must be discussed by both supplier and customer when any dispute happened.
- 3、 Must add new item on time when it is necessary.

■ Inspection specification

NO	Item	Criterion	AQL
01	Electrical Testing	1.1 Missing vertical, horizontal segment, segment contrast defect. 1.2 Missing character, dot or icon.	

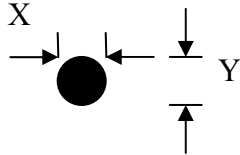
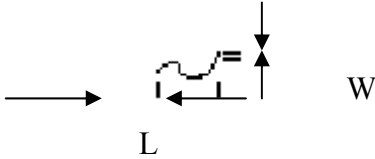
		1.3 Display malfunction. 1.4 No function or no display. 1.5 Current consumption exceeds product specifications. 1.6 LCD viewing angle defect. 1.7 Contrast defect	0.65																			
02	LCM black spots, white spots, bright spots, contamination, (display/non-display)	As following drawing $\Phi = (x+y)/2$  <table border="1"> <thead> <tr> <th></th> <th>Size</th> <th>Acceptable QTY</th> <th>Remark</th> </tr> </thead> <tbody> <tr> <td rowspan="4">Common dots defect</td> <td>$\Phi \leq 0.15$</td> <td>Ignore</td> <td>/</td> </tr> <tr> <td>$0.15 < \Phi \leq 0.25$</td> <td>2</td> <td>more than 5mm between two defects</td> </tr> <tr> <td>$0.25 < \Phi \leq 0.3$</td> <td>1</td> <td>/</td> </tr> <tr> <td>$0.3 < \Phi$</td> <td>0</td> <td>/</td> </tr> </tbody> </table>		Size	Acceptable QTY	Remark	Common dots defect	$\Phi \leq 0.15$	Ignore	/	$0.15 < \Phi \leq 0.25$	2	more than 5mm between two defects	$0.25 < \Phi \leq 0.3$	1	/	$0.3 < \Phi$	0	/	1.5		
	Size	Acceptable QTY	Remark																			
Common dots defect	$\Phi \leq 0.15$	Ignore	/																			
	$0.15 < \Phi \leq 0.25$	2	more than 5mm between two defects																			
	$0.25 < \Phi \leq 0.3$	1	/																			
	$0.3 < \Phi$	0	/																			
03	Scratches, line type contamination (display/non-display)	As following drawing  <table border="1"> <thead> <tr> <th>Length</th> <th>Width</th> <th>Acceptable QTY</th> <th>Remark</th> </tr> </thead> <tbody> <tr> <td>---</td> <td>$W \leq 0.03$</td> <td>Ignore</td> <td>/</td> </tr> <tr> <td>$L \leq 3.5$</td> <td>$0.03 < W \leq 0.05$</td> <td>3</td> <td rowspan="2">More than 5mm between two defects</td> </tr> <tr> <td>$L \leq 3$</td> <td>$0.05 < W \leq 0.08$</td> <td>3</td> </tr> <tr> <td>---</td> <td>$0.08 < W$</td> <td>0</td> <td>/</td> </tr> </tbody> </table>	Length	Width	Acceptable QTY	Remark	---	$W \leq 0.03$	Ignore	/	$L \leq 3.5$	$0.03 < W \leq 0.05$	3	More than 5mm between two defects	$L \leq 3$	$0.05 < W \leq 0.08$	3	---	$0.08 < W$	0	/	
Length	Width	Acceptable QTY	Remark																			
---	$W \leq 0.03$	Ignore	/																			
$L \leq 3.5$	$0.03 < W \leq 0.05$	3	More than 5mm between two defects																			
$L \leq 3$	$0.05 < W \leq 0.08$	3																				
---	$0.08 < W$	0	/																			

04	Polarizer bubbles	If bubbles are visible, judge using black spot specifications, not easy to find, must check in specify direction. <table border="1" data-bbox="480 286 1406 573"> <thead> <tr> <th>Size</th> <th>Acceptable QTY</th> <th>Remark</th> </tr> </thead> <tbody> <tr> <td>$\Phi \leq 0.5$</td> <td>ignore</td> <td>/</td> </tr> <tr> <td>$0.5 < \Phi \leq 1.0$</td> <td>2</td> <td>More than 5mm between two defects</td> </tr> <tr> <td>$1.0 < \Phi$</td> <td>0</td> <td>/</td> </tr> </tbody> </table>	Size	Acceptable QTY	Remark	$\Phi \leq 0.5$	ignore	/	$0.5 < \Phi \leq 1.0$	2	More than 5mm between two defects	$1.0 < \Phi$	0	/	1.5
Size	Acceptable QTY	Remark													
$\Phi \leq 0.5$	ignore	/													
$0.5 < \Phi \leq 1.0$	2	More than 5mm between two defects													
$1.0 < \Phi$	0	/													
05	TP black spots, white spots, concavo-convex spots, scratches (display/non-display)	5.1 spots <table border="1" data-bbox="480 689 1417 976"> <thead> <tr> <th>Size</th> <th>Acceptable QTY</th> <th></th> </tr> </thead> <tbody> <tr> <td>$\Phi \leq 0.2$</td> <td>ignore</td> <td></td> </tr> <tr> <td>$0.2 < \Phi \leq 0.3$</td> <td>2</td> <td>More than 5mm between two defects</td> </tr> <tr> <td>$0.3 < \Phi$</td> <td>0</td> <td></td> </tr> </tbody> </table>	Size	Acceptable QTY		$\Phi \leq 0.2$	ignore		$0.2 < \Phi \leq 0.3$	2	More than 5mm between two defects	$0.3 < \Phi$	0		1.5
		Size	Acceptable QTY												
		$\Phi \leq 0.2$	ignore												
		$0.2 < \Phi \leq 0.3$	2	More than 5mm between two defects											
		$0.3 < \Phi$	0												
		5.2 lines(not scratch): L:Length; W:Width <table border="1" data-bbox="480 1048 1385 1279"> <tbody> <tr> <td>$L \leq 10$</td> <td>$W \leq 0.05$</td> <td>Ignore</td> <td>/</td> </tr> <tr> <td>$L \leq 10$</td> <td>$0.05 < W \leq 0.10$</td> <td>2</td> <td>More than 5mm between two defects</td> </tr> <tr> <td>-----</td> <td>$0.1 < W$</td> <td>0</td> <td>/</td> </tr> </tbody> </table>	$L \leq 10$	$W \leq 0.05$	Ignore	/	$L \leq 10$	$0.05 < W \leq 0.10$	2	More than 5mm between two defects	-----	$0.1 < W$	0	/	1.5
$L \leq 10$	$W \leq 0.05$	Ignore	/												
$L \leq 10$	$0.05 < W \leq 0.10$	2	More than 5mm between two defects												
-----	$0.1 < W$	0	/												
5.3 lines(scratch): L:Length; W:Width <table border="1" data-bbox="480 1355 1445 1608"> <tbody> <tr> <td>$W \leq 0.03$</td> <td>Ignore</td> <td>/</td> </tr> <tr> <td>$L \leq 2.0, 0.03 < W \leq 0.05$</td> <td>2</td> <td rowspan="2">More than 5mm between two defects</td> </tr> <tr> <td>$L \leq 1.0, 0.05 < W \leq 0.1$</td> <td>2</td> </tr> <tr> <td>$L \geq 2.0, W \geq 0.05$ or $L \geq 1.0, W \geq 0.1$</td> <td>0</td> <td>/</td> </tr> </tbody> </table>	$W \leq 0.03$	Ignore	/	$L \leq 2.0, 0.03 < W \leq 0.05$	2	More than 5mm between two defects	$L \leq 1.0, 0.05 < W \leq 0.1$	2	$L \geq 2.0, W \geq 0.05$ or $L \geq 1.0, W \geq 0.1$	0	/	1.5			
$W \leq 0.03$	Ignore	/													
$L \leq 2.0, 0.03 < W \leq 0.05$	2	More than 5mm between two defects													
$L \leq 1.0, 0.05 < W \leq 0.1$	2														
$L \geq 2.0, W \geq 0.05$ or $L \geq 1.0, W \geq 0.1$	0	/													
TP Newton's ring and Interference fringes	a: Area of Newton's ring and Interference fringes A: Whole TP surface $a \leq 1/2 * A$	1.5													
TP Position disabled or losing	Not allowed	1.5													

06	Backlight elements	<p>6.1 Illumination source flickers when lit.</p> <p>6.2 Spots or scratches that appear when lit must be judged using LCD spot, lines and contamination standards.</p> <p>6.3 Backlight doesn't light or color is wrong</p>	<p>0.65</p> <p>1.5</p> <p>0.65</p>
07	Soldering	<p>7.1 No unmelted solder paste may be present on the PCB.</p> <p>7.2 No cold solder joints, missing solder connections, oxidation or icicle.</p> <p>7.3 No residue or solder balls on PCB.</p> <p>7.4 No short circuits in components on PCB.</p>	<p>0.65</p> <p>0.65</p> <p>1.5</p> <p>0.65</p>
08	General appearance	<p>8.1 No oxidation, contamination, curves or, bends on interface pin (OLB) of FPC</p> <p>8.2 No cracks on interface pin(OLB) of FPC</p> <p>8.3 NO contamination, solder residue or solder balls on product.</p> <p>8.4 The IC on the FPC may not be damaged, circuits.</p> <p>8.5 The residual rosin or tin oil of soldering (component or chip component) is not burned into brown or black color.</p> <p>8.6 Sealant on top of the ITO circuit has not hardened</p> <p>8.7 Pin type must match type in specification sheet.</p> <p>8.8 LCD pin loose or missing pins.</p> <p>8.9 Product packaging must the same as specified on packaging specification sheet.</p> <p>8.10 Product dimension and structure must conform to product specification sheet.</p>	<p>1.5</p> <p>0.65</p> <p>1.5</p> <p>0.65</p> <p>1.5</p> <p>1.5</p> <p>0.65</p> <p>1.5</p> <p>1.5</p>

◆ RELIABILITY

1. Environmental Test

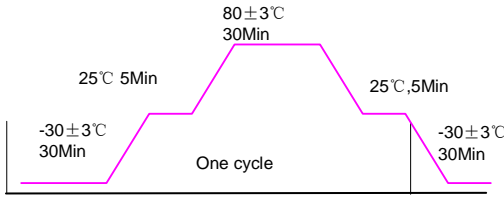
No	Test Item	Test Condition& Criteria	Sample Size	Determinant Stand.
1-1	High Temperature Operation	Temperature: $70 \pm 3^\circ\text{C}$; Humidity: Except; Test method: Operation Duration: 96Hrs	Sample Do: $\geq 2\text{PCS}$ On Going: $\geq 3\text{PCS}/\text{LOT}$	TS
1-2	Low temperature Operation	Temperature: $-20 \pm 3^\circ\text{C}$; Humidity: Except; Test method: Operation Duration: 96Hrs	Sample Do: $\geq 2\text{PCS}$ On Going: $\geq 3\text{PCS}/\text{LOT}$	TS
1-3	High Temperature / High Humidity Operation	Temperature: $60 \pm 3^\circ\text{C}$; Humidity: $95\% \pm 3\% \text{RH}$; Test method: Operation Duration: 96Hrs	Sample Do: $\geq 2\text{PCS}$ On Going: $\geq 3\text{PCS}/\text{LOT}$	TS
1-4	Temperature Shock test	Shock Temperature & Time:  Duration: 20cycles	Sample Do: $\geq 2\text{PCS}$ On Going: $\geq 3\text{PCS}/\text{LOT}$	TS
1-5	Temperature Cycle test	Normal temperature 2H \rightarrow $-30 \pm 3^\circ\text{C}$, 10H(3H) \rightarrow $60 \pm 3^\circ\text{C}$, $90 \pm 3\% \text{RH}$ 10H(3H) \rightarrow $80 \pm 3^\circ\text{C}$, 10H(2H) \rightarrow (25°C) 5 cycles	Sample Do: $\geq 2\text{PCS}$ On Going: $\geq 3\text{PCS}/\text{LOT}$	TS

Item	FAULT JUDGMENT CRITERIA
TS	1. No clearly visible defects or deterioration of display quality allowed. 2. No function – related abnormalities.

NOTE:

- When temperature moves, LCD's valve voltage will be influenced by it, which leads to LCD's contrast and chroma change.
- In high temperature operation and storage tests in MQE test will make LCD's power consumption increase. The reason is that a few crystal molecules are apart because of high temperature when there is a long time storage and operation in high temperature, which leads to decrease of gross resistance ratio of crystal molecules. Hence, LCD's power consumption go up than that of before test.

2. Mechanical Reliability Test

No.	Test Item	Test Condition& Criteria	Sample Size	Determinant Spec.
2-1	ESD test	Discharge modality: Contact voltage:±1KV、 ±2KV; Air voltage: ±2KV、 ±4KV、 ±6KV; (Discharge R=330Ω;C=150PF)	2PCS	No software error

3. Soldering

- (1) Soldering temperature: 340+/-10°C.
- (2) Available times for repeated soldering: 5 times
- (3) Attentions paid when soldering:
 - A. FPC's golden finger and soldering pad are butt-jointed before soldered. Tolerance is within the 1/3 width of golden finger and 0.5~1mm of FPC's length is allowed to be exposed in the jointed soldering pad.
 - B. Coat proper tin in the iron-head when soldering, with dragging speed of 2.5cm/sec.
 - C. The soldering part is warmed up first with iron-head when there is a rework. Then heat it up from one side until tin is melted, last, take off FPC.

4. FPC cable flexing and bending test

- Number of Bending / Flexing Cycles: <10 times
 Radius of the Bend Mandrels: >0.4 mm
 Degree of Bend: <180°

◆ SUGGESTIONS FOR USING LCD MODULES

● Handling of LCM

- (1) The LCD screen is made of glass. Don't give excessive external shock, or drop from a high place.
- (2) If the LCD screen is damaged and the liquid crystal leaks out, do not lick and swallow. When the liquid is attach to your hand, skin, cloth etc, wash it off by using soap and water thoroughly and immediately.
- (3) Don't apply excessive force on the surface of the LCM.
- (4) If the surface is contaminated, clean it with soft cloth. If the LCM is severely contaminated, use Isopropyl alcohol/Ethyl alcohol to clean. Other solvents may damage the polarizer. The following solvents are especially prohibited: water, ketone Aromatic solvents etc.
- (5) Exercise care to minimize corrosion of the electrode. Corrosion of the electrodes is accelerated by water droplets, moisture condensation or a current flow in a high-humidity environment.
- (6) Install the LCD Module by using the mounting holes. When mounting the LCD module make sure

it is free of twisting, warping and distortion. In particular, do not forcibly pull or bend the I/O cable or the backlight cable.

(7) Don't disassemble the LCM.

(8) To prevent destruction of the elements by static electricity, be careful to maintain an optimum work environment.

- Be sure to ground the body when handling the LCD modules.
- Tools required for assembling, such as soldering irons, must be properly grounded.
- To reduce the amount of static electricity generated, do not conduct assembling and other work under dry conditions.
- The LCD module is coated with a film to protect the display surface. Exercise care when peeling off this protective film since static electricity may be generated.

(9) Do not alter, modify or change the shape of the tab on the metal frame.

(10) Do not make extra holes on the printed circuit board, modify its shape or change the positions of components to be attached.

(11) Do not damage or modify the pattern writing on the printed circuit board.

(12) Absolutely do not modify the zebra rubber strip (conductive rubber) or heat seal connector

(13) Except for soldering the interface, do not make any alterations or modifications with a soldering iron.

(14) Do not drop, bend or twist LCM.

(15) If the LCM is assembled with touch panel, pay more attention to using touch panel.

* Please wear clean finger sacks, gloves and mask to protect the products from fingerprint or stain attach, and also hold the portion outside the view area when handling the panel.

* Please use finger sacks or gloves to avoid injuries by sharp edges when handling the Film-Glass type touch panel because a glass edges are not chamfered.

* Cautions for installing and assembling

- Do not give excessive strain to the product.
- Flexible pattern cable is connected to the TP body by heat-seal(thermal pressure) method. So, do not apply excessive forces to the flexible pattern.
- In order not to apply load on the surface of the touch panel, please keep a clearance of 0.2mm-0.5mm between product and case.
- Pressing inside of boundary of the frame(part(A) as shown in below) may cause fault operation, so please design to avoid pressing of touch panel at part (A) such as having gasket/cushion at part (C). Particularly the area (B) shall be free from burr. The gasket/cushion material at the part (C) should not be exceeded to inside of the boundary of the frame.

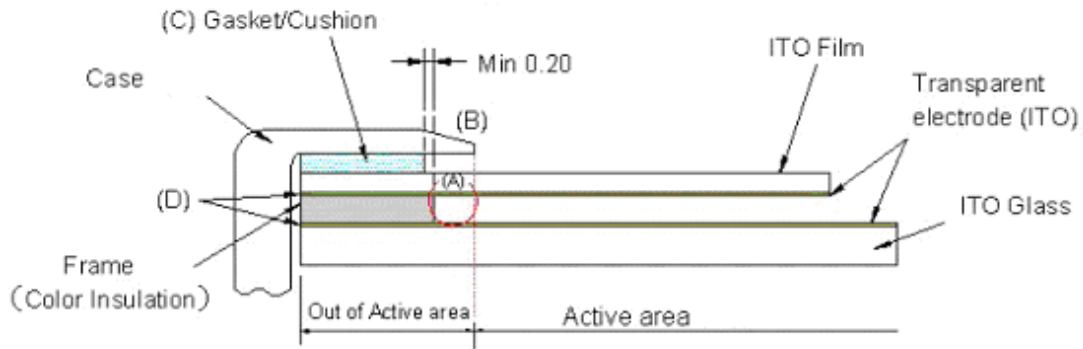

Do not make the following mistakes:

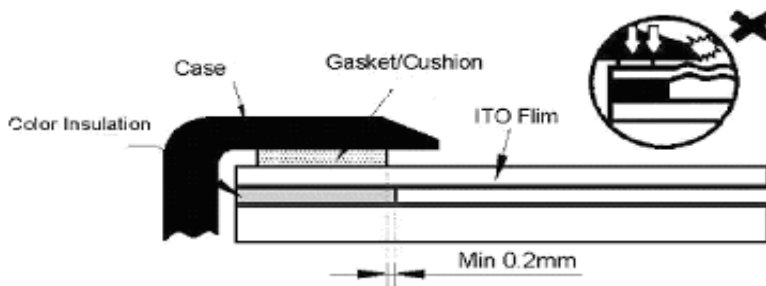

- When designing installment of case and touch panel, you would better consider to keep clearance of 0.2-0.3mm between touch panel and inside boundary of case.

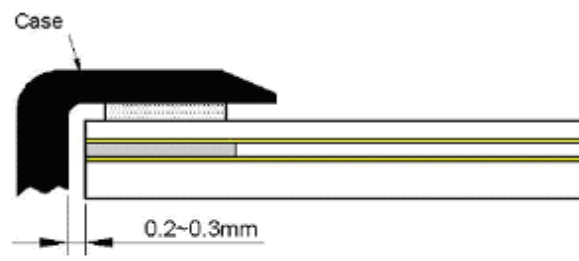

- Please keep your case flat in order not to touch with touch panel directly which causes serious damage of a transparent electrode.

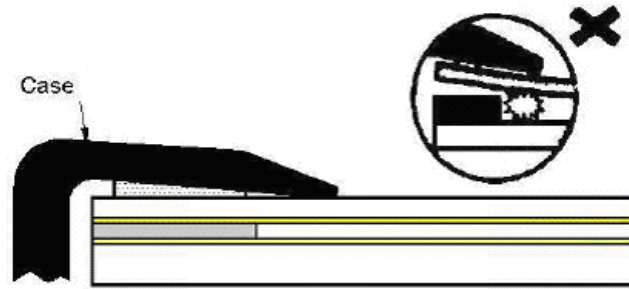

- Do not use any organic solvent or detergent other than ethanol.
- The corners of the product are not chamfered. When positioning and fixing the product on the case, we suggest that you would provide a R part on the corner of the case so as not to apply load on the corner of the transparent touch panel.

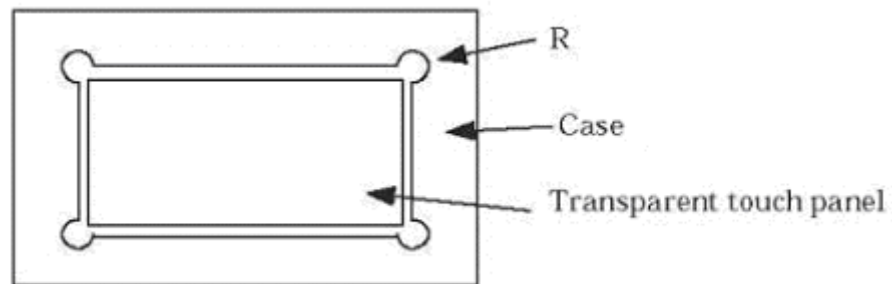

- Please confirm its characteristic in advance whether any damage is given to this product when attaching a protection sheet on this product at customer side. Some changes may arise in the characteristics of this product by the protection sheet attachment such as operation, cosmetic, etc.. However, those changes are out of our guarantee.

- **Storage**

- (1) Store in an ambient temperature of 5 to 45 °C, and in a relative humidity of 40% to 60%. Don't expose to sunlight or fluorescent light.
- (2) Storage in a clean environment, free from dust, active gas, and solvent.
- (3) Store in antistatic container.

◆ PACKING

● Packing Materials

NO.	ITEM	Dimension(LXWXH) (mm)	Quantity
1	Tray	424X295X12	6
2	Carton	437X307X163	84

● Packing Method

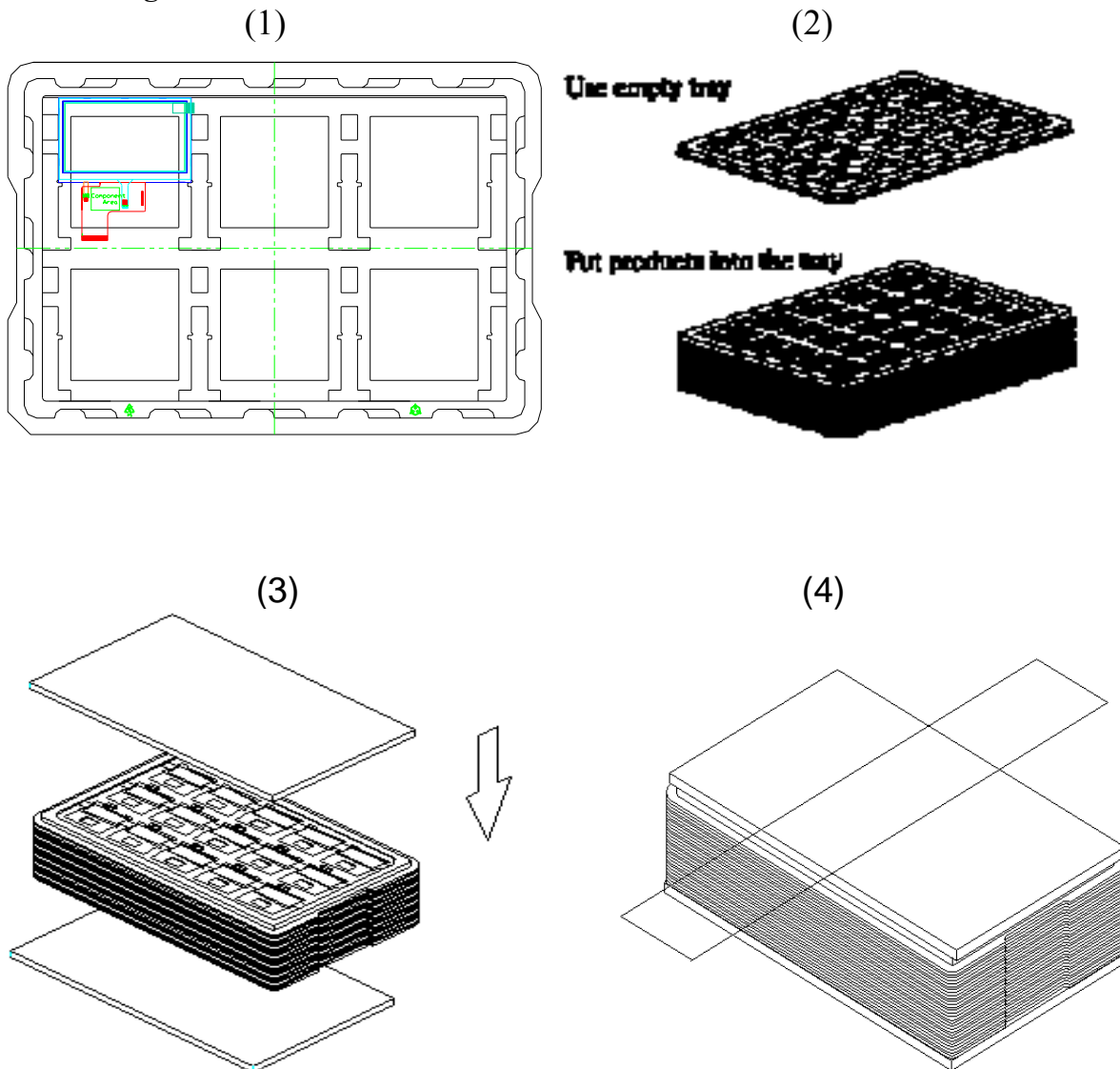

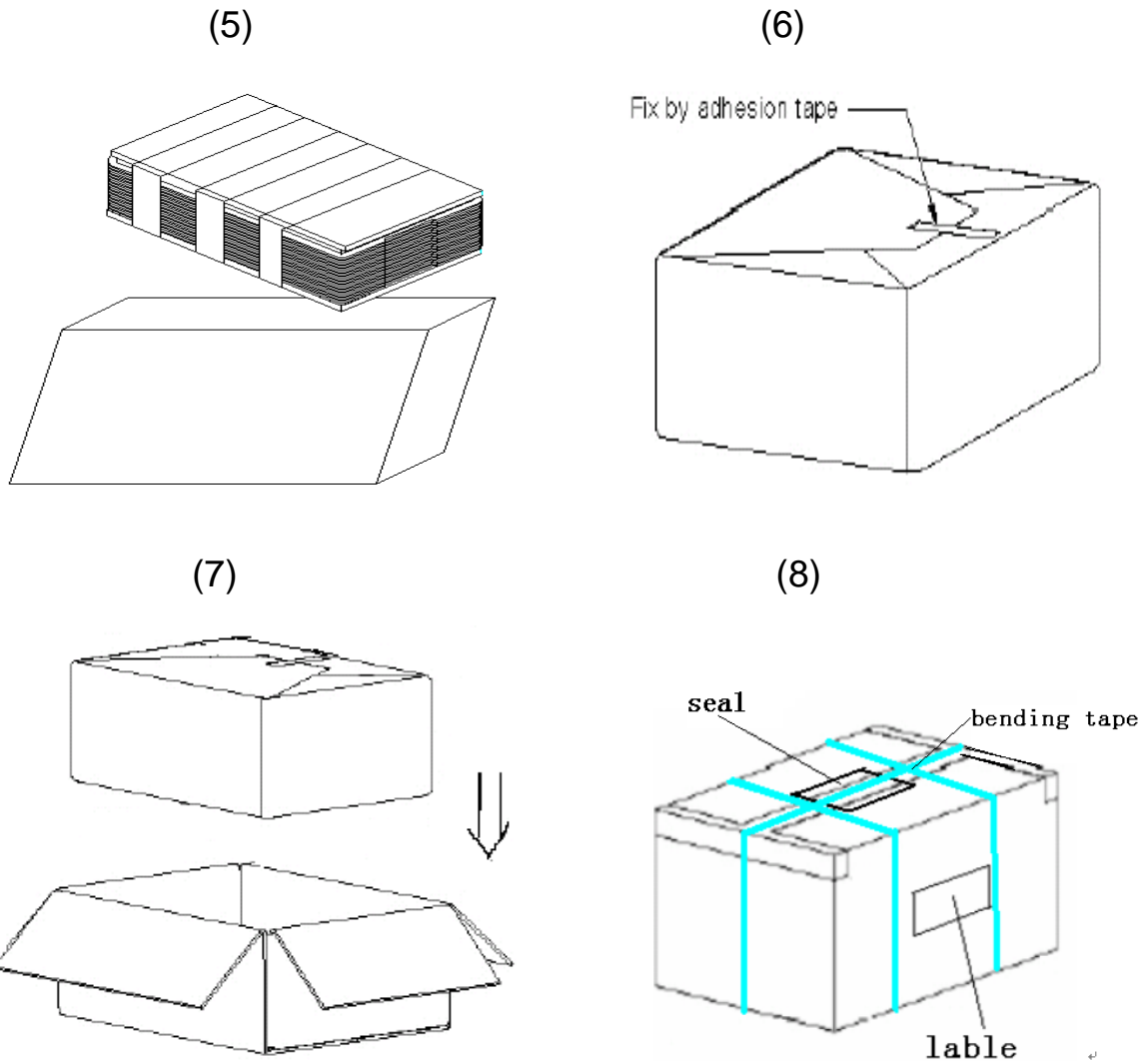

- (1). Put module into tray cavity :
- (2). Tray stacking
- (3). Put 1 cardboard under the tray stack and 1 cardboard above:
- (4). Fix the cardboard to the tray stack with adhesive tape:
- (5). Put the tray stack and 4 pcs desiccant into the LDPE bag
- (6). Fix the LDPE bag with adhesive tape:
- (7). Put LDPE bag with tray stack into carton.:
- (8). Carton sealing with adhesive tape.

◆ ENVIRONMENT-RELATED SUBSTANCES

- Meet with Environment-Related Substances Controlled Standard